

Lift-Off™ BAGLESS

USER'S GUIDE
3750 SERIES-220-240V



3 Safety Instructions

4 Product View

5-6 Assembly

6-10 Operation

10-13 Maintenance and Care

14 Troubleshooting

15 Consumer Services

15 Replacement Parts

16 Warranty



Thank you for buying a BISSELL Lift-Off™ Vacuum

We're glad you purchased a BISSELL Lift-Off vacuum. Everything we know about floor care went into the design and construction of this complete, high-tech home cleaning system.

Your BISSELL Lift-Off is well made, and we back it with a limited two year warranty. We also stand behind it with a knowledgeable, dedicated Consumer Services department, so, should you ever have a problem, you'll receive fast, considerate assistance.

My great-grandfather invented the floor sweeper in 1876. Today, BISSELL is a global leader in the design, manufacture, and service of high quality homecare products like your BISSELL Lift-Off.

Thanks again, from all of us at BISSELL.

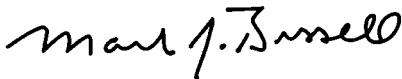

Mark J. Bissell
President and Chief Executive Officer

IMPORTANT SAFETY INSTRUCTIONS

When using an electrical appliance, basic precautions should be observed, including the following:

READ ALL INSTRUCTIONS BEFORE USING YOUR UPRIGHT VACUUM.

⚠ WARNING: To reduce the risk of fire, electric shock, or injury:

- Use indoors only.
- Do not leave machine when it is plugged in.
- Do not use with damaged cord or plug.
- If appliance is not working as it should, has been dropped, damaged, left outdoors, or dropped into water, return it to a service agent.
- Do not handle unit with wet hands.
- Do not pull or carry by cord, use cord as a handle, close door on cord, pull cord around sharp corners or edges, run appliance over cord, or expose cord to heated surfaces.
- Do not unplug by pulling on cord. Unplug by grasping plug.
- Do not run appliance over cord.
- Do not handle plug or appliance with wet hands.
- Do not expose hair, loose clothing, fingers or body parts to openings or moving parts.
- Do not pick up hot or burning objects such as cigarettes, matches, or hot ashes.
- Do not pick up flammable or combustible materials (lighter fluid, petrol, kerosene, etc.) or use in the presence of explosive liquids or vapour.
- Do not use appliance in an enclosed space filled with vapours given off by oil base paint, paint thinner, some moth proofing substances, flammable dust, or other explosive or toxic vapours.
- Not intended for use by young children or infirm persons without supervision.
- Young children should be supervised to ensure that they do not play with the appliance.
- Remove plug from electrical outlet before cleaning or maintaining the appliance.
- If the supply cord is damaged, it must be replaced by the manufacturer or its service agent in order to avoid a hazard.
- Do not pick up toxic material (chlorine bleach, ammonia, drain cleaner, petrol, etc.).
- Do not allow to be used as a toy.
- Do not use for any purpose other than described in this User's Guide.
- Use only manufacturer's recommended attachments.
- Do not use with any opening blocked; keep free of dust, lint, hair, and anything that may reduce air flow.
- Keep appliance on a level surface.
- Turn off all controls before unplugging.
- Be extra careful when cleaning stairs.
- This appliance is provided with double insulation. Use only identical replacement parts.
- Do not use without debris tank and/or filters in place.
- Pay close attention when working around children.

SAVE THESE INSTRUCTIONS.

THIS MODEL IS FOR HOUSEHOLD USE ONLY.

IMPORTANT

FOR OPERATION ON A 220-240 VOLT A.C. 50/60 Hz POWER SUPPLY ONLY.

FOR RESIDENTS OF THE UNITED KINGDOM ONLY

If your appliance is fitted with a nonrewireable BS 1363 plug it must not be used unless a 13 amp (ASTA approved to BS 1362) fuse is fitted in the carrier contained in the plug. (Spares may be obtained from your BISSELL supplier). If for any reason the plug is cut off, it must be disposed of, as it is an electric shock hazard should it be inserted into a 13 amp socket.

Product view

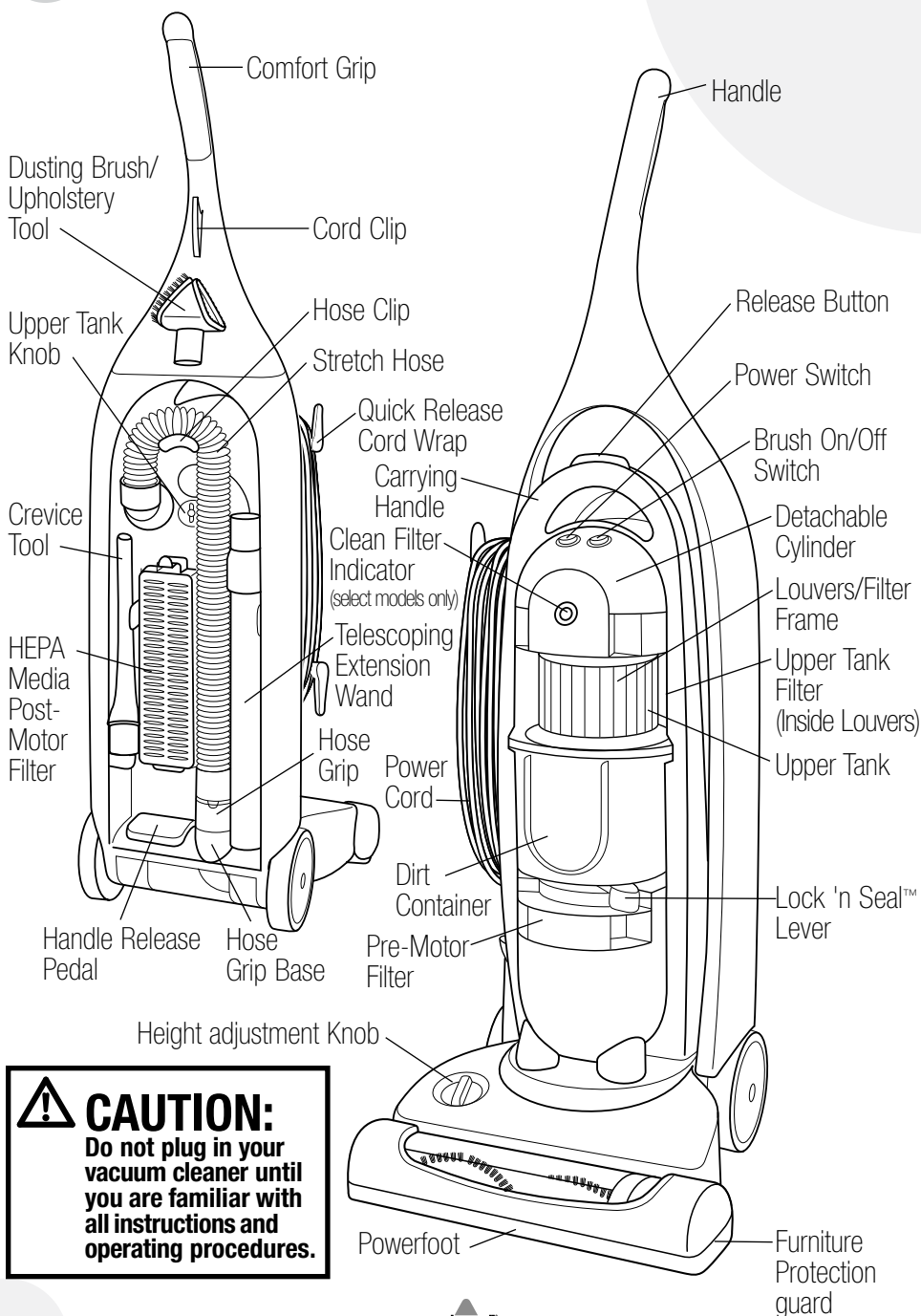

⚠ CAUTION:
 Do not plug in your vacuum cleaner until you are familiar with all instructions and operating procedures.



How to put it together

This user's guide has been designed to help you get the most satisfaction from your BISSELL Lift-Off. You'll find assembly and operating instructions, safety precautions, as well as maintenance and troubleshooting instructions. Please read this user's guide thoroughly before assembling your vacuum cleaner.

Pay particular attention to the product diagram, assembly instructions, and part names. Locate and organize all parts before assembly. Familiarize yourself with the parts and where they go. Following this user's guide will greatly enhance your ability to get the most performance from your BISSELL Lift-Off for many years.

Assembly

The only tool you'll need to assemble your vacuum cleaner is a Phillips screwdriver.

Attach handle to vacuum

1. Locate the vacuum handle and remove the screw packet taped to the base of the handle.
2. Stand the vacuum upright and slide the base of the handle firmly into the grooves at the top of the vacuum body.
3. Check to be sure the handle is fitted to the vacuum body. If there is a gap in front, continue to push firmly until the handle is flush.
4. Insert two of the screws from the screw packet into the existing holes. Tighten securely with a screwdriver.



WARNING:

Do not plug in your cleaner until you have completely assembled it per the following instructions and are familiar with all instructions and operating procedures.



WARNING:

Plastic film can be dangerous. To avoid danger of suffocation, keep away from babies and children.

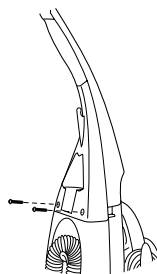
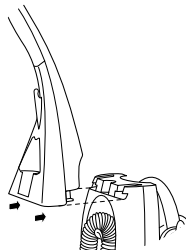

Assembly

Attach vacuum hose and tools

1. Position the Twist 'n Snap hose assembly on the vacuum and line up the tabs on the base of the hose with the corresponding notches. Turn the Twist 'n Snap hose to the right to lock into place.

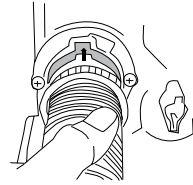

2. Slide the end of the hose grip onto the hose grip base. Place the hose into the hose clip.

NOTE: The Powerfoot will not operate effectively unless the hose is firmly attached to the base.

3. Snap the telescoping extension wand, crevice tool, and combination tool into the storage clips as shown.
4. On board TurboBrush™ (select models only). The TurboBrush bracket slides onto the hanger on the front of the handle. Attach the bracket by aligning the slots with the rectangular part on the hanger as shown and pulling down until it is locked into place.

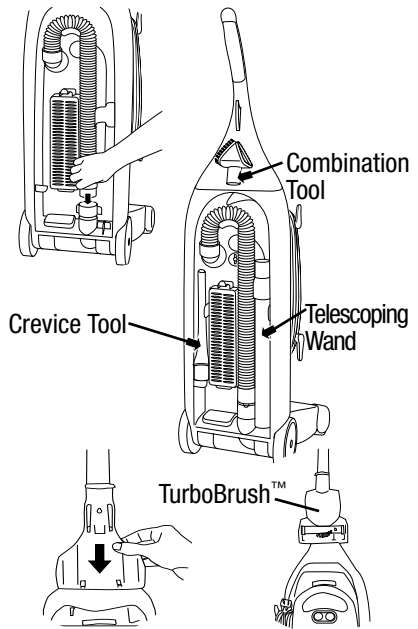

NOTE: If you do not wish to store the TurboBrush on your Lift-Off vacuum, the bracket may be hung on a wall for storage and hanger may be removed from the vacuum.

Place the TurboBrush in the bracket by aligning the small holes near the brush roll with the tabs at the bottom of the bracket and snap the TurboBrush into place.

Operation

Power switch/brush switch

The power switch is located just below the handle on the front of the detachable cylinder. Push the rocker switch “ON” (I) to vacuum, and “OFF” (O) when cleaning is complete.



CAUTION:

Before using your vacuum, make sure that the dirt container and upper tank are in locked position and that all filters (upper tank, pre-motor and post-motor) are in place. Do not operate your vacuum without these Filters.

Operation

Power switch/brush switch continued

The brush switch is located just below the handle on the front of the detachable cylinder next to the power switch. This switch turns the rotating brush on and off. The brush switch should be in the "ON" (I) position for normal carpet cleaning. You may want to turn the brush switch "OFF" (O) for bare floor cleaning or other delicate surfaces.

NOTE: Your BISSELL Lift Off vacuum is equipped with a special internal switch that turns the rotating brush off whenever the unit is in the upright position.

Handle positions

1. Upright – For storage and above floor cleaning with tools.
2. Normal cleaning – Press the handle release pedal with your foot to recline.

Power height adjustment

The Powerfoot on your BISSELL Lift-Off can be adjusted to clean several floor surfaces.

NOTE: For optimal cleaning performance, adjust to the lowest practical setting. If your cleaner is difficult to push, adjust to the next higher setting.

1. Place handle in upright position.
2. Turn height adjustment knob to desired setting.
 - Lowest Setting** – For bare floors.
 - Medium Settings** – For short and medium pile carpets.
 - Highest Setting** – For plush pile carpet.

NOTE: You may also adjust the setting while in the normal cleaning position.

Tip:

Your vacuum feature a Quick Release Cord Wrap. To remove the power cord quickly and easily, rotate the upper cord wrap towards floor, and slip power cord from upper and lower cord wraps.

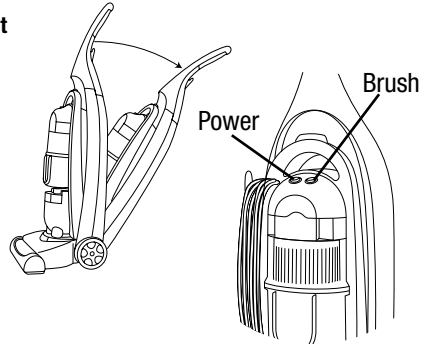

Tip:

Before cleaning under low furniture, check area first for objects that might harm the unit or block the vacuum hose.

ATTENTION BERBER CARPET OWNER:

Some BERBER carpets have a tendency to fuzz with wear. Repeated passes with your vacuum over the same area may aggravate this condition. Consider using the highest height setting or turning off the rotating brush for this type of carpet.

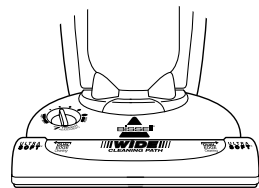

Operation

Special tools

Your BISSELL Lift-Off is not only a powerful floor vacuum cleaner, it's also a versatile stairs and above floor vacuum when you select one of the special tools.

NOTE: The tools can be used with the vacuum in the upright position or with the detachable cylinder.

1. Detach the vacuum hose by grasping the hose grip and lifting to separate from the hose grip base.
2. Attach tools by firmly pushing onto vacuum hose or telescoping extension wand.

Combination dusting brush/upholstery tool:

Two types of cleaning tools are included in one attachment; rotate for desired tool.

- Use brush side to dust furniture, blinds, books, lamps, shelves and baseboards.
- Use upholstery side for curtains, draperies, cushions and fabrics.

Crevice tool:

Use in tight narrow spaces.

Stair cleaning tool: (select models)

Use for stairs, area rugs and other small carpeted areas. This tool can also be used for **bare floors**.

Note: The stair cleaning tool does not store on board.

Telescoping extension wand:

Use with desired attachment for a longer reach. To extend the wand, twist the collar to "Unlock" position and push away from you. Twist the collar to the "Lock" position to lock into place. To retract, twist to unlock, pull toward you and twist to relock.

TurboBrush™ (Select Models):

Use rotating brush action for small areas such as stairs and upholstery.

Note: Press gently when using TurboBrush to gain maximum cleaning. Too much pressure could cause the brush to stop rotating.

Deluxe bare floor tool (Select Models):

Use for bare floors. Swivel head turns to get into tight spaces and fits under cabinets.

Note: The deluxe bare floor tool does not store on board.

All items may not be included with your model. More tools are available; to order please refer to page 15.

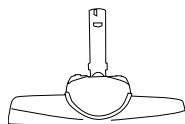
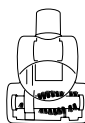
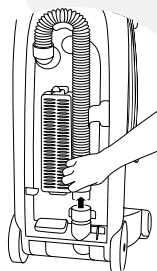

CAUTION:

Always place vacuum cleaner on floor in its fully upright position and make sure it is locked into place before removing cylinder or when using tools. Placing the Lift-Off in its full upright position automatically stops the rotating brush.

Operation

Cleaning with the detachable cylinder

The detachable cylinder feature makes it possible to easily take the powerful cleaning action of your BISSELL Lift-Off to stairways, auto interiors, and other hard-to-reach areas in your home.

Before detaching the cylinder, your Lift-Off must be in its fully upright position. You do not need to turn off the power first.

1. Press the release button at the top of the cylinder handle and lift the cylinder to remove.
2. Detach the vacuum hose from the hose grip base at the back of the cylinder.
3. Attach the desired tool(s) to the hose grip at the end of the vacuum hose.
4. When you're done, remove the tool(s) and reconnect the hose to the hose grip base.
5. Return the cylinder to the powerfoot by aligning the "feet" on the front with the bumps on the foot of the upright vacuum. Push the cylinder toward the vacuum frame until it "clicks" into place.

Shoulder strap

Select Models Only

The shoulder strap may be used while cleaning with the detachable cylinder.

1. To attach the shoulder strap, wrap the velcro ends attached to the bottom of the strap securely around the cylinder handle as shown.
2. The length of the strap may be adjusted as required for comfort.

Clean filter indicator

Select models only

The clean filter indicator tells you when airflow in the vacuum is reduced due to dirty filters or a clog in the hose. The clean filter indicator will remain green until the airflow is reduced. At that time, it begins to change to red. When it is fully red, the airflow is significantly reduced or blocked. Follow the steps on pages 10-11 to clean your filter. All filters in the vacuum should be cleaned or replaced when the clean filter indicator turns red.

If the indicator remains red after all filters have been cleaned, follow the steps on page 13 to check for and clear clogs.

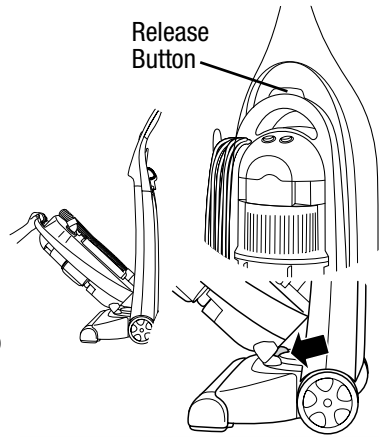

NOTICE:

While vacuuming, certain carpets and low humidity conditions may generate small static discharges. The discharges are entirely harmless and are not associated in any way with the main power supply.



CAUTION:

While the vacuum is in use, warm air is emitted through the post-motor filter on the back of the cylinder. The bottom of the cylinder may also become warm. When using the shoulder strap, to avoid discomfort, position the cylinder so that these parts are not directed towards or touching your body.



CAUTION:

Do not press the release button while using the carrying handle to transport the vacuum cleaner. The cylinder could detach causing the rest of the vacuum to fall.

Operation

Power cord storage

When you are done using your BISSELL Lift-Off, return it to the upright position and store the power cord.

1. Turn vacuum cleaner off (O).
2. Unplug power cord by grasping the plug (NOT the cord) and disconnect from outlet.
3. Loop power cord around cord wraps on side of the cylinder.

Transporting cleaner

1. To move your vacuum cleaner from room to room, put the handle in the upright position, tilt the cleaner back on its rear wheels and push forward.
2. The cleaner can also be moved by using the carrying handle on the detachable cylinder.

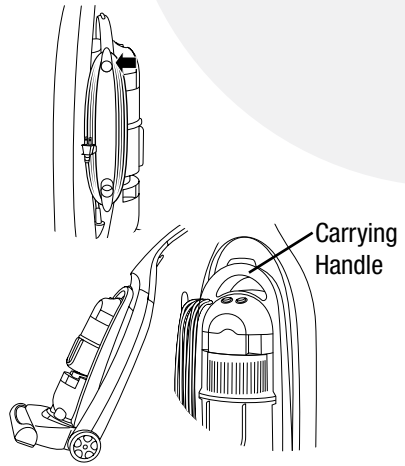

Maintenance and care

To maintain maximum cleaning performance, the following maintenance steps must be performed:

1. Empty the dirt container when the dirt reaches the "Full" line on the side.
2. Check the upper tank and pre-motor filters at least once a month and clean and replace as needed.
3. Replace the HEPA media post-motor filter every six months.

NOTE: More frequent filter cleaning may be necessary if you are vacuuming new carpet, fine dust, or have allergy concerns.

Follow the instructions on the following pages to perform these simple maintenance steps.

Empty dirt container

The Dirt Container needs to be emptied when the dirt reaches the "Full" line on the side of the container.

1. Unplug cleaner from electrical outlet.
2. Slide the Lock 'n Seal lever to the "Unlock" position.
3. Grasp handle and pull the dirt container straight out to remove from vacuum.
4. Empty dirt into garbage container.
5. Put the dirt container back in the vacuum and slide the lever to the "Lock" position.

NOTE: The dirt container may be washed in warm water with a mild detergent. Make sure it is completely dry before replacing.



WARNING: To reduce the risk of electric shock, turn power switch OFF and disconnect plug from electrical outlet before performing maintenance or troubleshooting checks.

Tip:

For maximum cleaning performance, check and clean or replace all filters as suggested.

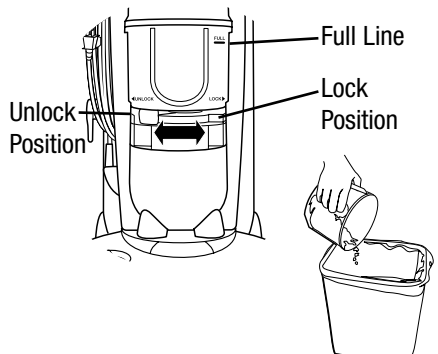

Maintenance and care

Cleaning the upper tank & filter

Use only **BISSELL** replacement filters in your **BISSELL Lift-Off**.

1. Unplug the cleaner from electrical outlet.
2. The upper tank filter can be reached by removing the dirt container, reaching underneath the upper tank and turning the rim of the filter frame to unlock. Pull straight down to remove. Brush the dirt off the louvers and upper tank filter.
3. The foam upper tank filter may be removed and hand washed in cold water with mild detergent. Rinse well then air dry thoroughly before replacing.
4. The upper tank and louvers may also be wiped clean with a damp cloth.

NOTE: For easier access, the entire upper tank may be removed by turning the knob on the back of the cleaner to unlock and pulling the entire tank straight out.

Cleaning the pre-motor & post-motor filters

Use only **BISSELL** replacement filters in your **BISSELL Lift-Off**.

1. Unplug the cleaner from electrical outlet.
2. The pre-motor filter protects the motor from dirt particles. It is located in the slide out tray underneath the dirt container. If the filter becomes dirty, pull out the tray, lift out the filter and clean. This filter may be hand washed in cold water with mild detergent. Rinse well and air dry thoroughly before replacing.
3. The HEPA media post-motor filter assists in the filtration process to return clean air to the room. It is located behind the door on the back of the cleaner. If the filter becomes dirty, open the door, remove the filter and replace. The HEPA media filter is not washable.



WARNING:

Do not operate cleaner with damp or wet filters or without all filters in place.

IMPORTANT:

To maximize your cleaning performance and extend the life of your vacuum, it is very important that you check and clean your filters frequently.

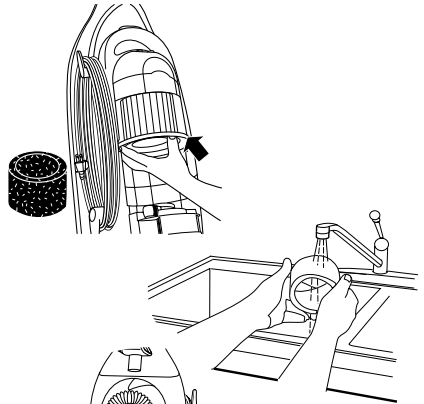

Upper Tank Knob

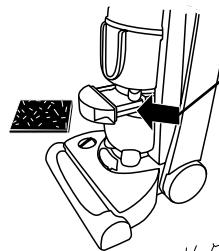
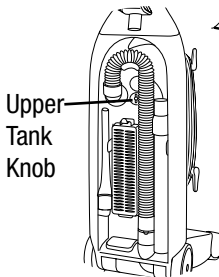

Pre-Motor Filter

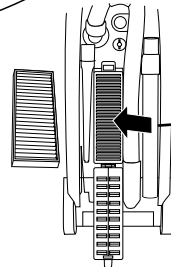

HEPA Media Post-Motor Filter

Maintenance and care

Check rotating brush and drive belt

You should check your vacuum cleaner's rotating floor brush and drive belt regularly for wear or damage. You should also clean the brush and brush ends of strings, hair, and carpet fibres. These can wrap around the brush and hamper its ability to effectively clean your carpet. Also remove any debris that has accumulated under the brush cover.

1. Unplug cleaner from electrical outlet.
2. Remove detachable cylinder from vacuum cleaner.
3. Recline handle and turn vacuum cleaner over so bottom side is up.
4. Remove the six screws as shown with a Phillips head screwdriver. Lift the brush cover off.
5. Grasp rotating floor brush at both ends and lift.
6. Clean strings, hair and other debris from rotating floor brush, paying special attention to brush ends.
7. Clean strings, hair and other debris from motor pulley and drive belt areas.
8. Check drive belt carefully for wear, cuts or stressed areas. If any damage is present, discard old drive belt and replace.
9. Check air passageway for obstructions. Remove debris from this area.

Replace drive belt

Use only BISSELL replacement belts in your BISSELL Lift-Off.

1. Unplug cleaner from electrical outlet.
2. With rotating floor brush removed from vacuum cleaner (Steps 1-5 of Check rotating floor brush and drive belt), grasp old drive belt and remove from motor pulley. Discard old drive belt.
3. Place new drive belt over motor pulley and stretch other end over rotating floor brush in the space between the bristles.
4. Place ends of rotating floor brush down into slots on sides as shown.
5. Turn rotating floor brush by hand several times in the direction of motor pulley. If properly installed, drive belt will center itself on rotating brush crown.
6. Reposition brush cover and screws. Tighten screws securely.



CAUTION:

To reduce the risk of injury from moving parts, turn **Power Switch OFF** and **disconnect plug** from electrical outlet.

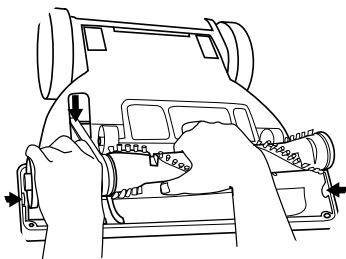
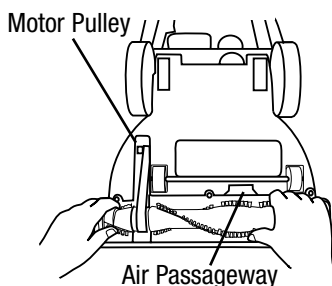
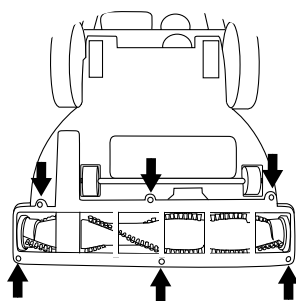

Maintenance and care

TurboBrush maintenance

Select Models Only

The TurboBrush should be checked regularly for clogs or debris wrapping around the brush roll.

Unplug vacuum from electrical outlet.

If a clog is present or debris is visible, unscrew the two screws on the back of the TurboBrush to remove the faceplate and clear any obstructions.

To clean debris from the brush roll, remove the screw located on the belt cover. Lift the belt cover. Remove the brush roll from the drive belt and clean debris.

Reposition the drive belt on the brush roll. Place ends of brush roll in slots on sides as shown. Reposition belt cover and secure with shorter screw. Reposition faceplate and secure with two longer screws.

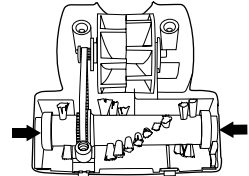
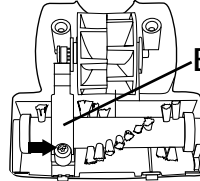
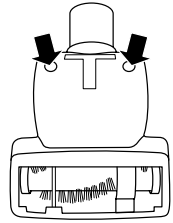

Maintenance and care

Cleaning clogs

Low suction or poor pickup may be due to a clog in the vacuum cleaner. If you notice a change in the sound of the motor or a reduction in the spinning action, check for clogs.

1. Unplug cleaner from electrical outlet.
2. Empty dirt container.
3. Check upper tank for build up or clogs.
4. Remove the upper tank and check the suction inlet for a clog.
5. Grasp the hose grip and lift to separate from the suction opening. Check for a clog in the base or the hose.
6. Release the hose from the vacuum by turning to the left. Straighten the hose and unclog with a long, narrow object.
7. If the clog persists, follow the instructions for checking the rotating brush on page 12 and inspect the air passageway for obstructions.

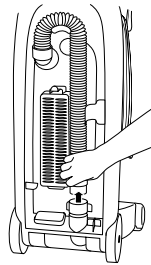
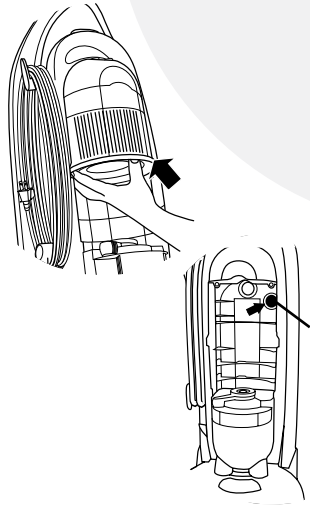

Maintenance and care

Thermal protector

An internal thermal protector has been designed into your cleaner to protect it from overheating. When the thermal protector activates, the main vacuum motor will stop operating. If this happens, proceed as follows:

1. Turn the cleaner off (O) and unplug from electrical outlet.
2. Check the upper tank area, pre-motor filter and post-motor filter for dirt accumulation.
3. Refer to the "Clearing clogs" section above.
4. When the motor **cools for approximately 30 minutes**, the thermal protector automatically resets and cleaning may continue. If the thermal protector continues to activate after following the above steps, your cleaner may need servicing.

NOTE: The thermal protector controls the main vacuum motor only, not the brush motor. If the thermal protector activates, the brush will continue to operate normally; however, there will be no suction.

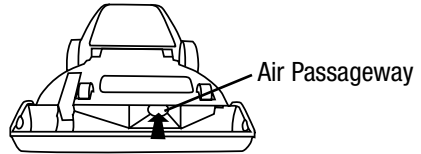

CAUTION:

To reduce the risk of injury from moving parts, turn power switch OFF and disconnect plug from electrical outlet.

Troubleshooting



WARNING:

To reduce the risk of injury from moving parts and/ or electrical shock, turn power switch OFF and disconnect plug from electrical outlet before performing troubleshooting checks.

Vacuum cleaner won't run.

Possible causes

1. Power cord not firmly plugged in
2. Thermal protector activated

Remedies

1. Check electrical plug
2. Allow cleaner to cool for 30 minutes, see pg. 15

No power at rotating floor brush.

Possible causes

1. Cylinder is not securely seated
2. Brush switch turned to off (O)
3. Vacuum is in upright position

Remedies

1. Remove cylinder and replace, making sure that it "clicks" into place
2. Make sure brush switch is in on (I) position
3. Recline vacuum to operate brush

Vacuum cleaner or tools won't pick up dirt.

Possible causes

1. Incorrect height adjustment
2. Hose not attached to suction opening
3. Crack or hole in hose
4. Drive belt broken, worn or off motor pulley
5. Rotating floor brush bristles worn
6. Rotating floor brush jammed
7. Clog in vacuum
8. Dirt container full
9. Dirt container or upper tank not installed properly
10. Filters are dirty

Remedies

1. Adjust powerfoot to correct height setting
2. Grasp hose grip and firmly push onto the base
3. Check hose and replace if needed
4. Reposition or replace drive belt, see pg. 12
5. Replace brush
6. Remove brush and clean debris from brush ends
7. Follow instructions on pg. 14 for clearing clogs
8. Empty dirt container
9. Position correctly and lock in place
10. Check and clean or replace upper tank, pre-motor and post-motor filters

Troubleshooting

Vacuum cleaner is difficult to push.

Possible causes

1. Incorrect height adjustment

Remedies

1. Adjust powerfoot to correct height setting

Visible dirt escaping from cleaner.

Possible causes

1. Dirt container full
2. Filters missing or installed incorrectly
3. Dirt container installed incorrectly

Remedies

1. Empty dirt Container
2. Check upper tank, pre-motor and post-motor filters for correct installation
3. Pull out and re-insert dirt container correctly

Other maintenance or service not included in the manual should be performed by an authorized service representative.

Thank you for selecting a BISSELL product.

Please do not return this product to the store.

BISSELL Consumer Services

If your BISSELL product should require service:

In the UK, Australia or New Zealand, call BISSELL Consumer Services at the numbers below and we will give you the location of a BISSELL Authorized Service Center in your area. For all other countries, contact your local in country distributor for questions, service, or repair.

If you have questions about your warranty or need replacement parts please contact the numbers below.

For UK inquiries:

Monday - Thursday 9 am — 5 pm
Friday 9 am — 4 pm

BISSELL Homecare (Overseas) Inc.

The Boat Yard
105 Straight Road
Old Windsor
Berkshire, SL4 2SE
United Kingdom
Telephone: 0870-225-0109

For New Zealand inquiries:

Monday - Friday 9 am — 5 pm

Parex Industries Ltd.

103 Central Park Drive
Henderson
Auckland
New Zealand
Telephone: 0800-247-735

Or visit the BISSELL website - www.bissell.com

When contacting BISSELL, have model number of unit available.

Please record your Model Number: _____

Please record your Purchase Date: _____

Note: Please keep your original sales receipt. It provides proof of date of purchase in the event of a warranty claim. See Warranty on page 20 for details.

Please do not return this product to the store.

For Australian inquiries:

Monday - Friday 9 am — 5 pm

BISSELL AUSTRALIA PTY LIMITED

Unit 35
15 Ricketts Road
Mount Waverley, Victoria 3149
Australia
Telephone: 1-800-811-183

For all other inquiries:

Monday - Friday 8 am — 4 pm

BISSELL Homecare, Inc.

PO Box 1888
Grand Rapids, MI 49501 USA
Telephone: 01-616-453-4451
Fax: 01-616-453-1383

Replacement parts

Item	Part No.	Part Name
1	3200	Style 8 Drive Belt (2-Pack)
2	203-1063	Crevice Tool
3	203-1099	Dusting Brush/Upholstery Tool
4	203-6624	Stair Cleaning Tool (Select Models)
5	203-6625	Telescoping Extension Wand
6	203-2081	Deluxe Bare Floor Tool (Select Models)
7	203-1227	TurboBrush (Select Models)
8	203-2082	Bracket Assembly for TurboBrush (Select Models)
9	203-5542	Shoulder Strap (Select Models)
10	203-2073	Twist 'n Snap Hose
11	203-6619	Brush Roll (Red)
12	3091	Style 8 HEPA Media Post-Motor Filter
13	203-1085	Upper Tank Filter
14	203-1073	Pre-Motor Filter

1

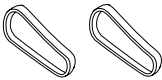

2

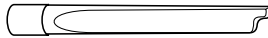

3



4

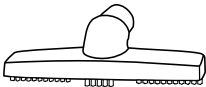

5

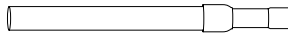

6

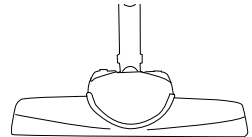

7

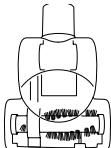

8

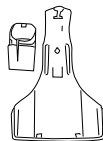

9

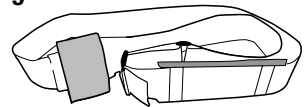

10



11



12

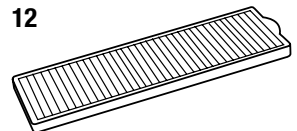

13



14



Warranty

This warranty gives you specific legal rights, and you may also have other rights which may vary from country to country. If you need additional instruction regarding this warranty or have questions regarding what it may cover, please contact BISSELL Consumer Services by telephone, or regular post as described below, or contact your local in country distributor.

Limited Two Year Warranty

Subject to the *EXCEPTIONS AND EXCLUSIONS identified below, BISSELL Homecare, Inc., will replace (with new or remanufactured components), at BISSELL's option, free of charge from the date of purchase by the original purchaser, for two years any defective or malfunctioning part do to manufacturers defect.

This warranty applies to product used for personal, and not commercial or rental service. This warranty does not apply to fans or routine maintenance components such as filters, belts, or brushes. Damage or malfunction caused by negligence, abuse, or use not in accordance with the User's Guide is not covered.

For UK inquiries:

Monday - Thursday 9 am — 5 pm
Friday 9 am — 4 pm

BISSELL Homecare (Overseas) Inc.

The Boat Yard
105 Straight Road
Old Windsor
Berkshire, SL4 2SE
United Kingdom
Telephone: 0870-225-0109

For Australian inquiries:

Monday - Friday 9 am— 5 pm

BISSELL AUSTRALIA PTY LIMITED

Unit 35
15 Ricketts Road
Mount Waverley, Victoria 3149
Australia
Telephone: 1-800-811-183

For New Zealand inquiries:

Monday - Friday 9 am — 5 pm

Parex Industries Ltd.

103 Central Park Drive
Henderson
Auckland
New Zealand
Telephone: 0800-247-735

For all other inquiries:

Monday - Friday 8 am — 4 pm

BISSELL Homecare, Inc.

PO Box 1888
Grand Rapids, MI 49501 USA
Telephone: 01-616-453-4451
Fax: 01-616-453-1383

BISSELL HOMECARE INC. IS NOT LIABLE FOR INCIDENTAL OR CONSEQUENTIAL DAMAGES OF ANY NATURE ASSOCIATED WITH THE USE OF THIS PRODUCT. BISSELL'S LIABILITY WILL NOT EXCEED THE PURCHASE PRICE OF THE PRODUCT.

*EXCEPTIONS AND EXCLUSIONS FROM THE TERMS OF THE LIMITED WARRANTY

THIS WARRANTY IS EXCLUSIVE AND IN LIEU OF ANY OTHER WARRANTIES EITHER ORAL OR WRITTEN. ANY IMPLIED WARRANTIES WHICH MAY ARISE BY OPERATION OF LAW, INCLUDING THE IMPLIED WARRANTIES OF MERCHANTABILITY AND FITNESS FOR A PARTICULAR PURPOSE, ARE LIMITED TO THE TWO YEAR DURATION FROM THE DATE OF PURCHASE AS DESCRIBED ABOVE.



©2007 BISSELL Homecare, Inc
Grand Rapids, Michigan
All rights reserved. Printed in China
Part Number 110-4012
Rev 9/07
Visit our website at:
www.bissell.com

Scotchgard is a trademark of 3M

